



SPARE PARTS LIST

SURFACE PREPARATION EQUIPMENT

PG 280, from Serial number 2014 140001
and forward, 2014-06

C PG 280
Chassi

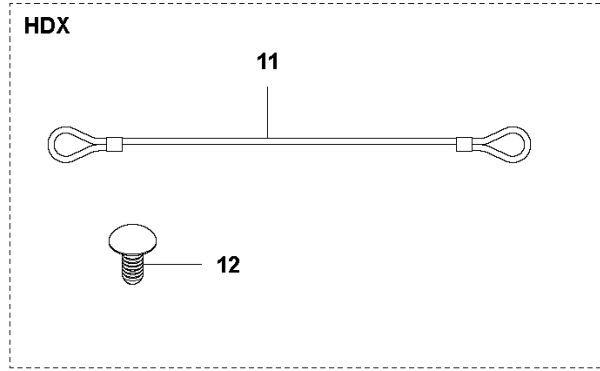
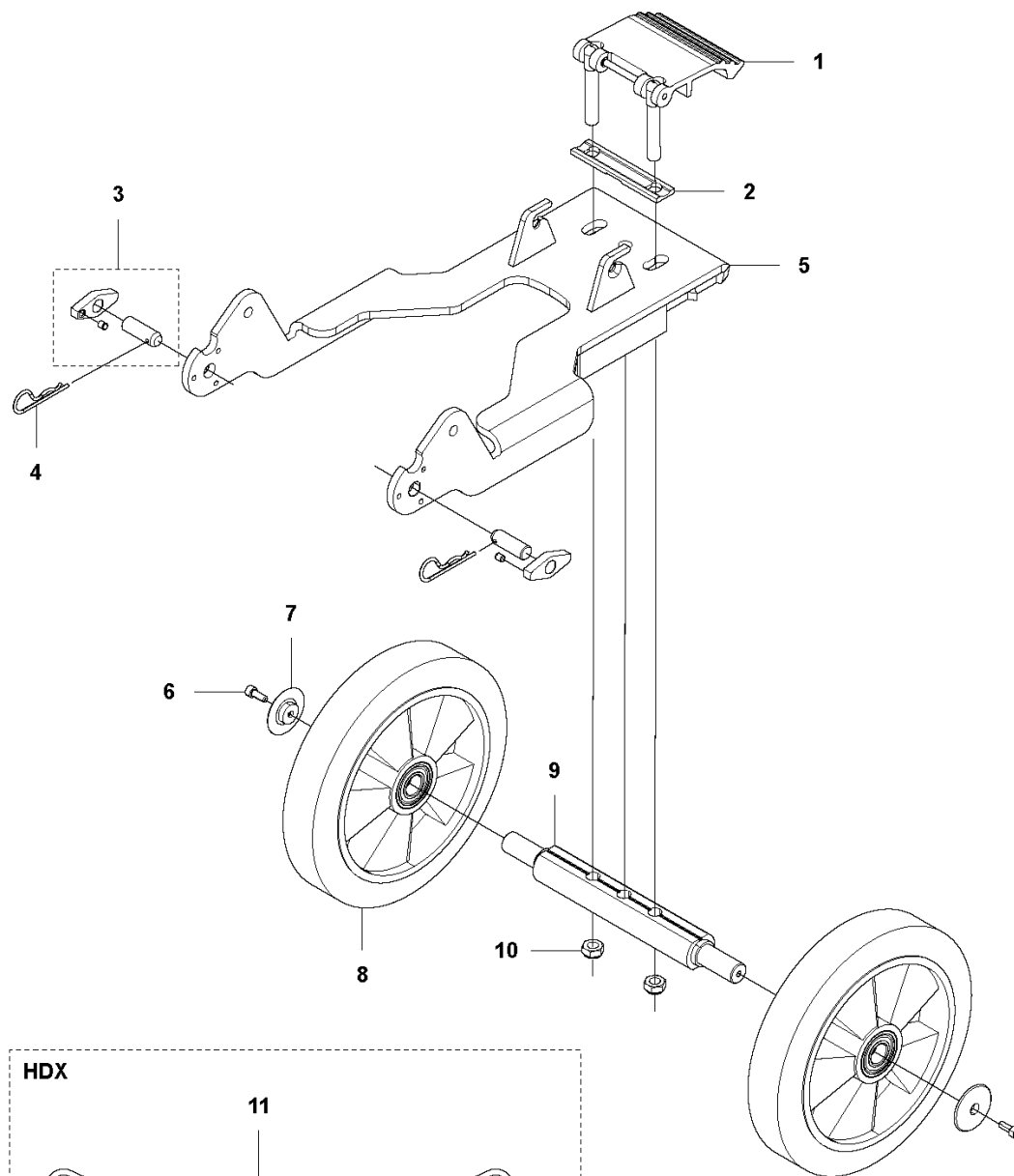

Ref	Part No	Description	Remark	QTY KIT
1	587 03 29-01	PEDAL ASSY		1
2	586 92 75-01	WASHER		1
3	586 99 17-01	BOLT		2
3	586 99 17-03	BOLT	HDX variant only	2
4	721 68 02-51	SPRING COTTER		2
5	585 14 05-01	FRAME		1
6	725 53 68-51	SCREW IHSCM		2
7	501 32 12-01	WASHER		2
8	504 18 55-01	WHEEL		2
9	585 14 12-01	AXLE		1
10	732 25 22-01	HEXAGON LOCKING NUT		2
11	586 29 64-01	WIRE	HDX variant only	4
12	586 82 91-01	RIVET	HDX variant only	6

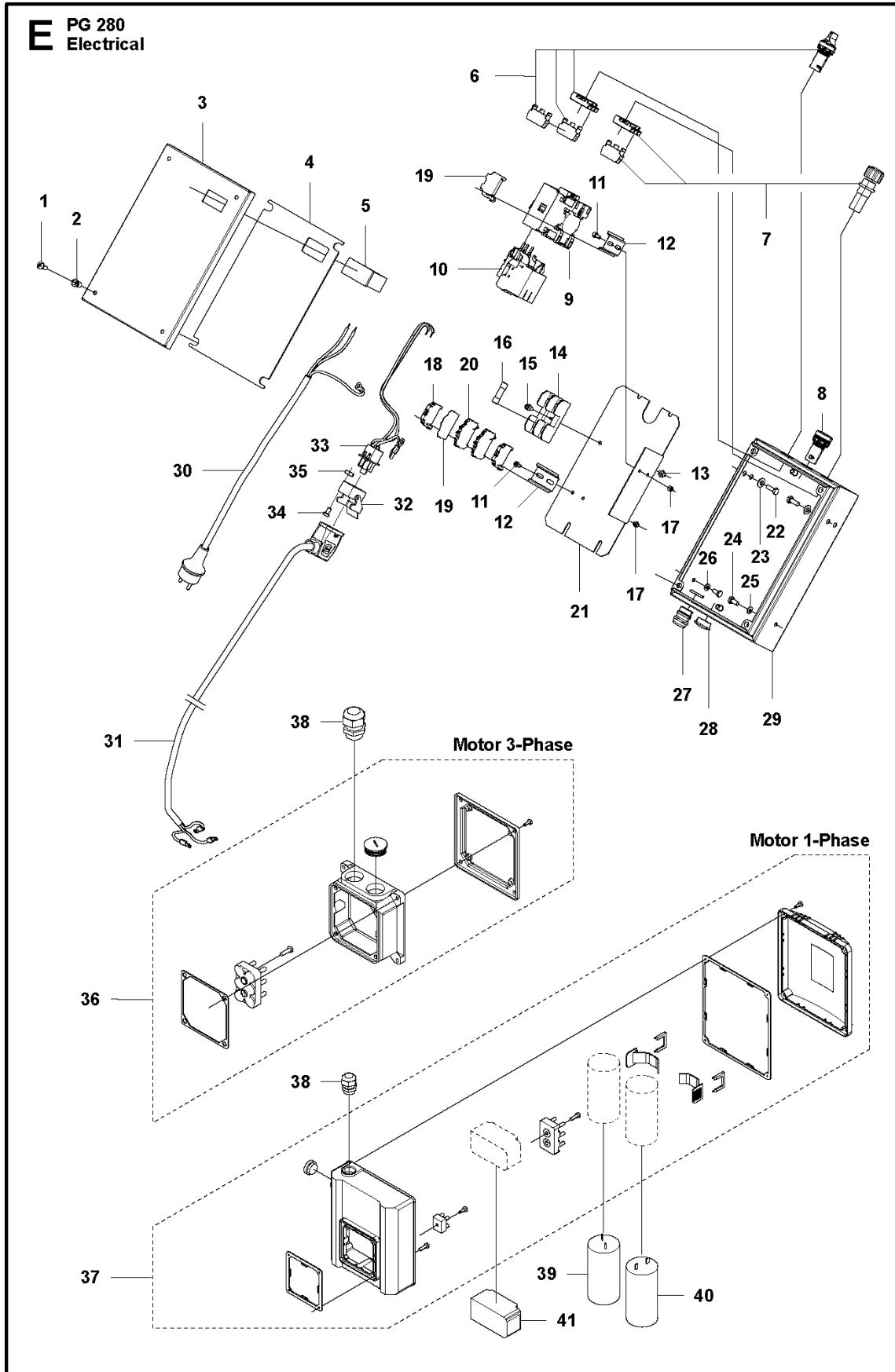

ELECTRICAL

PG 280, from Serial number 2014 140001 and forward, 2014-06

Ref	Part No	Description	Remark	QTY KIT
1	724 13 68-51	SCREW CRPANM		4
2	521 88 66-01	RIVET		4
3	586 47 43-01	LID		1
3	586 47 43-03	LID	HDX version only	1
4	586 46 70-01	SEALING	Attach with double-sided tape	1
5	584 29 63-01	HOUR METER		1
6	586 99 15-01	SWITCH KIT		1
7	586 99 16-01	SWITCH KIT		1
8	584 29 71-01	LAMP	230V	1
8	584 29 71-02	LAMP	110V	1
8	584 29 71-03	LAMP	400V	1
9	585 36 58-03	CONTACTOR	400-480V, 50/60Hz	1
9	585 36 58-01	CONTACTOR	200-230V, 50/60Hz	1
9	585 36 58-02	CONTACTOR	100-120V, 60Hz	1
9	586 99 18-01	CONTACTOR	100-120V, 50Hz	1
10	584 29 78-06	RELAY	3 phase	1
10	584 29 78-01	RELAY	1 phase, 220-240V, 60Hz	1
10	580 62 35-02	PROTECTION	1 phase, 220-240V, 50Hz	1
10	580 62 35-01	PROTECTION	1 phase, 100-120V, 60Hz	1
10	584 29 78-05	RELAY	1 phase, 100-120V, 50Hz	1
11	725 53 25-01	SCREW IHSCM		4
12	522 74 70-01	RAIL		2
13	731 23 16-01	HEXAGON NUT		1
14	525 88 26-01	FUSE HOLDER		1
15	725 53 64-55	SCREW IHSCM		1
16	525 63 81-01	FUSE		2
17	732 25 14-01	HEXAGON LOCKING NUT		4
18	585 36 61-05	TERMINAL BLOCK		3
19	585 36 61-03	TERMINAL BLOCK		1
19	585 36 61-07	TERMINAL BLOCK	US 1ph 100-120V	1
20	585 61 35-01	TERMINAL BLOCK	2pcs for 1ph and 3pcs for 3ph machines	2
20	585 36 61-01	TERMINAL BLOCK	US 1ph 100-120V	2
21	585 59 38-01	PLATE		1
22	725 24 51-71	SCREW EHHM		4
23	734 11 63-01	WASHER		4
24	725 23 66-71	SCREW EHHM		2
25	734 11 52-01	WASHER		1
26	735 21 53-01	LOCKWASHER		1
27	575 48 98-01	GROMMET		1
27	587 10 12-01	GROMMET	US 1-Phase	1
28	586 58 69-01	PLUG		1
28	586 58 69-02	PLUG	US 1-Phase	1
29	586 47 42-01	BOX		1
29	586 47 42-02	BOX	HDX version only	
30	586 23 68-03	CABLE	1 phase	1
30	586 23 78-01	CABLE	3 phase	1
30	586 23 68-02	CABLE	1 phase, AUS	1
30	586 23 68-06	CABLE	1 phase, UK	1
30	586 23 68-12	CABLE	1 phase, US 120V	1
30	586 23 68-13	CABLE	1 phase, US 240V	1
30	586 23 68-08	CABLE	1 phase BR	1
30	586 23 68-05	CABLE	1 phase JP	1
31	585 63 81-07	CABLE	3 phase	1
31	585 63 81-08	CABLE	1 phase, UK and JP	1
31	585 63 81-10	CABLE	1 phase US/CAN 220-240V	1
31	585 63 81-11	CABLE	1 phase US/CAN 100-120V	1
32	587 06 15-01	CONNECTOR		1
33	585 36 66-02	CONNECTOR		1
34	725 52 24-01	SCREW		2
35	732 25 10-01	HEXAGON LOCKING NUT		2
36	587 17 39-02	ELECTRONIC BOX	3 Phase	1

ELECTRICAL

PG 280, from Serial number 2014 140001 and forward, 2014-06

Ref	Part No	Description	Remark	QTY KIT
37	587 17 39-01	ELECTRONIC BOX	1 ph 230V, 50Hz	1
38	587 17 42-02	GROMMET	3 Phase	1
38	587 17 42-01	GROMMET	1 phase	1
38	587 16 33-01	GROMMET	1ph 100-120V kit	1
39	587 17 45-01	CAPACITOR	208-230V, 50/60 Hz	1
39	587 17 45-02	CAPACITOR	110V, 50/60 Hz	1
40	587 17 44-01	CAPACITOR	230V, 50Hz	1
40	587 17 44-02	CAPACITOR	208-230V, 60 Hz	1
40	587 17 44-03	CAPACITOR	110V, 50/60 Hz	1
41	587 17 43-01	SWITCH	230V, 50Hz	1
41	587 17 43-02	SWITCH	208-230V, 60Hz	1
41	587 17 43-03	SWITCH	110V, 50-60 Hz	1

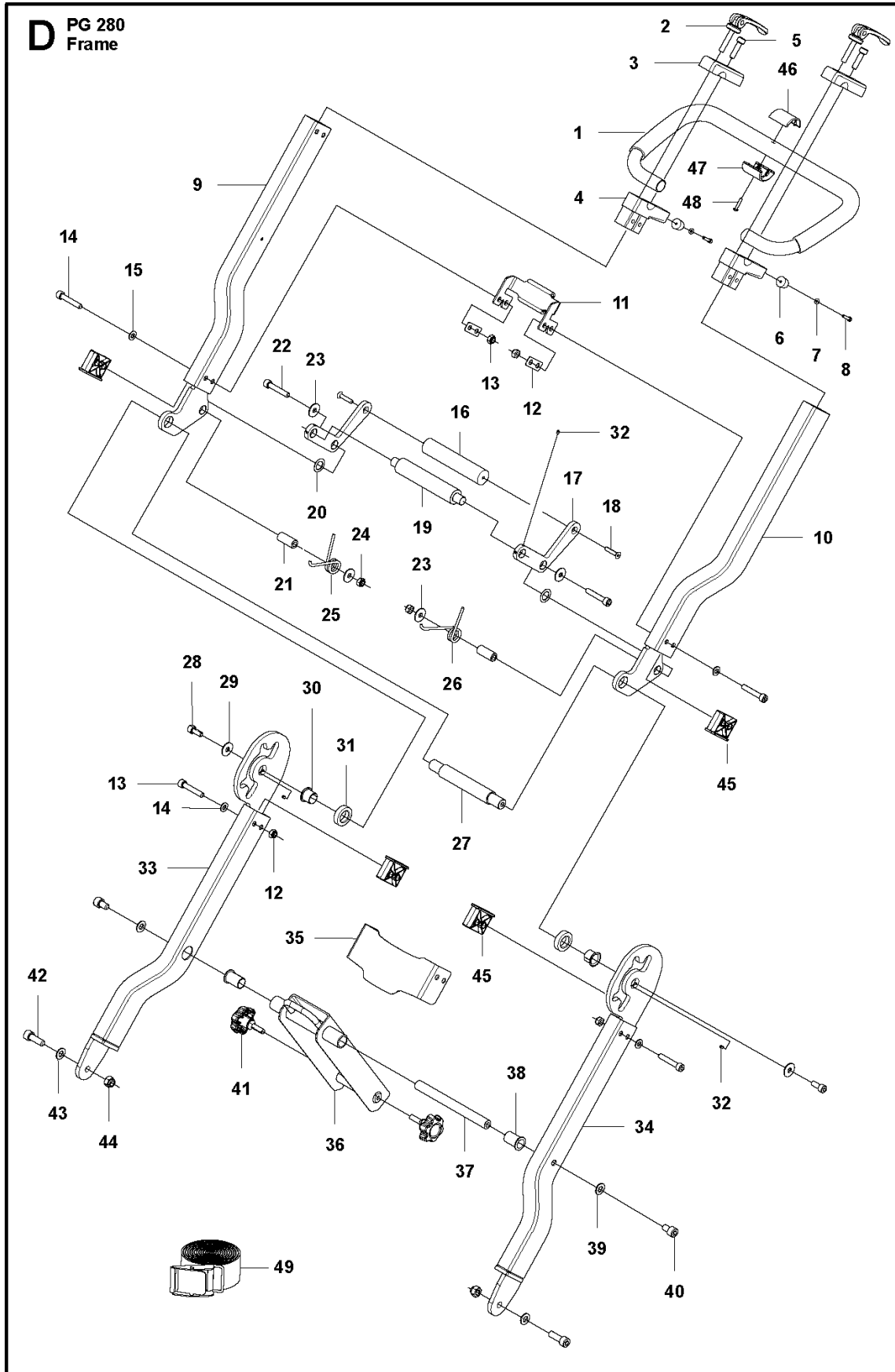

Ref	Part No	Description	Remark	QTY KIT
1	585 14 40-01	HANDLE		1
2	585 12 92-01	LOCKING HANDLE		2
3	585 51 66-01	BRACKET		2
4	585 51 67-01	BRACKET		2
5	725 54 55-21	SCREW IHSCM		2
6	585 51 68-01	RUBBER SHOE		2
7	734 11 36-01	WASHER		2
8	725 52 95-01	SCREW IHSCM		2
9	585 57 35-01	FORK		1
10	585 57 35-02	FORK		1
11	585 38 28-02	BRACKET		1
12	585 38 31-01	WASHER		2
13	732 25 18-01	HEXAGON LOCKING NUT		8
14	725 54 60-01	SCREW IHSCM		8
15	734 11 63-01	WASHER		8
16	585 13 37-02	HANDLE		1
17	585 13 33-01	PLATE		2
18	725 63 74-51	SCREW		2
19	585 13 38-02	ROD		1
20	585 41 62-01	WASHER		2
21	585 38 33-01	SLEEVE		2
22	725 54 61-01	SCREW IHSCM		2
23	734 11 65-41	WASHER		4
24	732 25 18-01	HEXAGON LOCKING NUT		2
25	585 41 73-01	SPRING		1
26	585 41 61-01	SPRING		1
27	585 13 36-02	TUBE		1
28	725 54 51-01	SCREW IHSCM		2
29	734 11 65-41	WASHER		2
30	585 41 60-01	BUSH		2
31	585 13 35-01	SPACER		2
32	728 82 85-01	SCREW IHSETM		6
33	585 16 21-01	FORK		1
34	585 16 21-02	FORK		1
35	585 38 30-02	BRACKET		1
35	585 38 30-04	BRACKET	HDX variant only	1
36	585 14 18-01	SUPPORT		1
37	585 12 90-01	TUBE		1
38	585 12 91-01	BUSH		2
39	734 11 72-01	WASHER		2
40	725 54 89-01	SCREW IHSCM		2
41	586 91 28-01	KNOB		2
42	725 54 95-01	SCREW IHSCM		2
43	734 11 72-01	WASHER		2
44	732 25 20-01	HEXAGON LOCKING NUT		2
45	585 13 29-01	SPACER		4
46	587 15 85-01	COVER		1
47	587 15 86-01	COVER		1
48	729 52 61-71	SCREW CRPANT		1
49	584 61 87-01	STRAP		1

B PG 280
Grinding Head

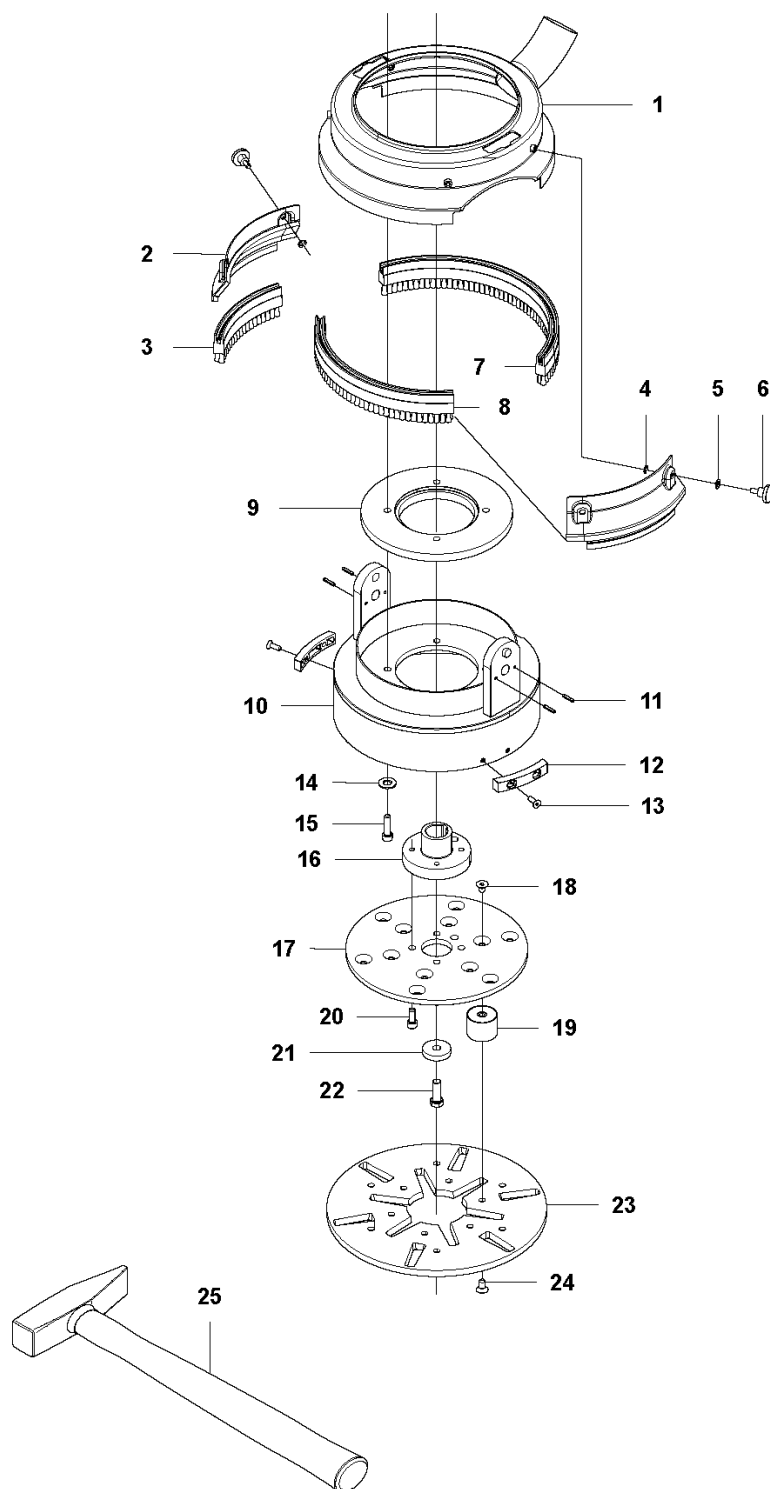

GRINDING HEAD

PG 280, from Serial number 2014 140001 and forward, 2014-06

Ref	Part No	Description	Remark	QTY KIT
1	585 13 87-01	COVER		1
2	586 99 93-01	COVER LID		2
3	585 13 84-03	BRUSH		2
4	735 58 35-01	WASHER		4
5	734 11 52-60	WASHER		4
6	510 36 16-01	SCREW		4
7	585 13 84-02	BRUSH		1
8	585 13 84-06	BRUSH		1
9	585 52 44-01	SPACER		1
10	585 12 83-01	MOUNTING PLATE		1
10	585 12 83-02	MOUNTING PLATE	HDX variant only	1
11	721 42 56-01	SPRING PIN		4
12	585 41 11-01	BRACKET		2
13	725 63 69-01	SCREW IHCSFM		4
14	734 11 63-01	WASHER		4
15	725 54 55-21	SCREW IHSCM		4
16	585 51 47-01	HUB		1
17	510 21 30-01	ATTACHMENT PLATE		1
18	725 64 47-55	SCREW IHCSFM		6
19	510 21 31-01	DAMPER		6
20	725 54 51-55	SCREW IHSCM		4
21	510 23 51-01	WASHER		1
22	725 24 95-71	SCREW EHHM		1
23	586 79 67-01	HOLDER		1
24	725 64 49-55	SCREW IHCSFM		6
25	522 03 97-01	HAMMER		1

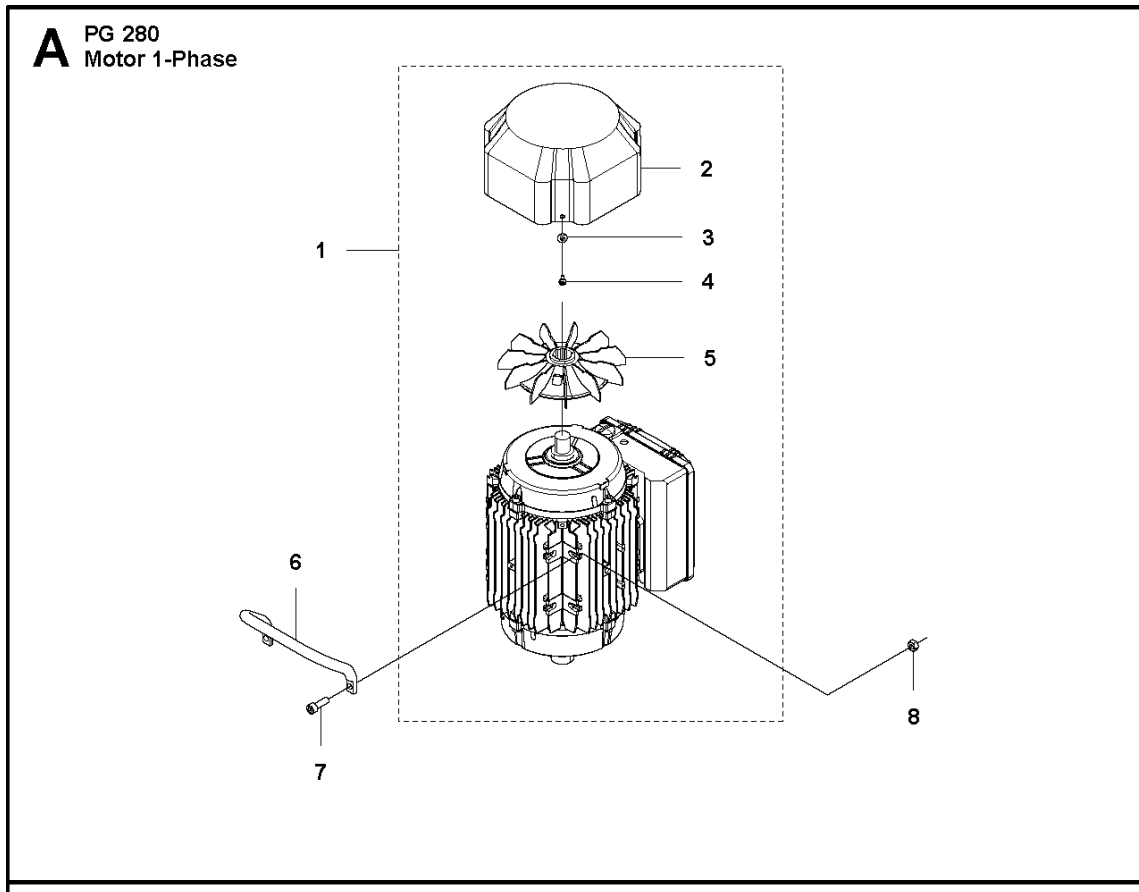

MOTOR 1-PHASE

PG 280, from Serial number 2014 140001 and forward, 2014-06

Ref	Part No	Description	Remark	QTY	KIT
1	585 30 19-01	MOTOR	220-240V, 50Hz	1	
1	585 30 19-02	MOTOR	220-240V, 60Hz	1	
1	585 30 21-01	MOTOR	100-120V, 50Hz	1	
1	585 30 21-02	MOTOR	100-120V, 60Hz	1	
2	587 17 46-01	FAN COVER		1	1
3	734 11 46-01	WASHER		4	1
4	724 13 23-01	SCREW CRPANM		4	1
5	587 17 47-01	FAN		1	1
6	585 42 33-01	HANDLE		1	
7	725 54 51-01	SCREW IHSCM		2	
8	731 23 18-01	HEXAGON NUT		2	

A PG 280
Motor 3-Phase

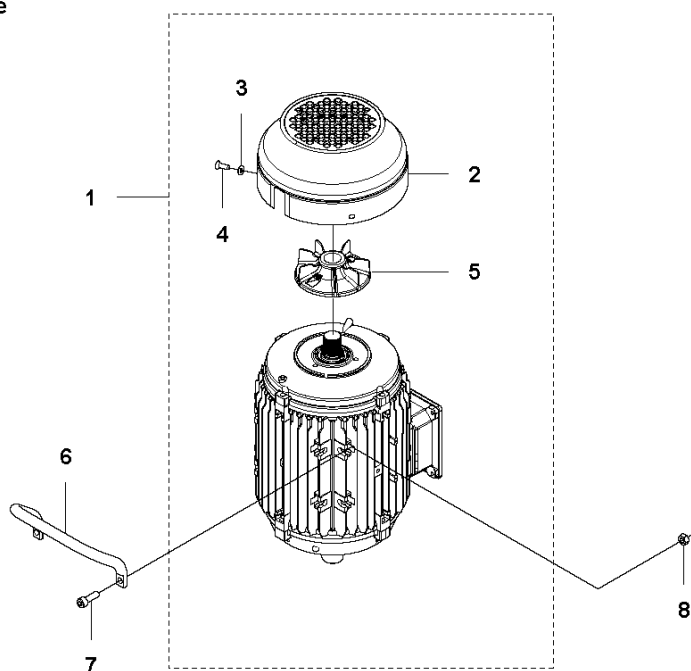

MOTOR 3-PHASE

PG 280, from Serial number 2014 140001 and forward, 2014-06

Ref	Part No	Description	Remark	QTY KIT	
1	585 26 39-01	MOTOR	3 phase, 400V, 50Hz	1	
2	587 17 46-03	FAN COVER		1	1
3	734 11 46-01	WASHER		3	1
4	724 13 23-01	SCREW CRPANM		3	1
5	587 17 47-03	FAN		1	1
6	585 42 33-01	HANDLE		1	
7	725 54 51-01	SCREW IHSCM		2	
8	731 23 18-01	HEXAGON NUT		2	